

KOSO HAMMEL DAHL

CONTROL VALVES

KOSO HAMMEL DAHL
4 Manley Street
West Bridgewater, MA 02379

tel: 508.584.1199
fax: 508.584.2525
www.hammeldahl.com

Installation, Maintenance & Operating Instructions

IMO - Type D

DIRECT-ACTING LINEAR SPRING DIAPHRAGM ACTUATORS

STANDARD SPECIFICATIONS

Model	Diaphragm (Effective area in square inches)	Standard Strokes (in inches)
DA	56	¾, 1, 1¼
DB	84	¾, 1, 1¼, 1½
DC	140	¾, 1, 1¼, 1½, 2, 2¼
DD	240	1½, 2, 2¼

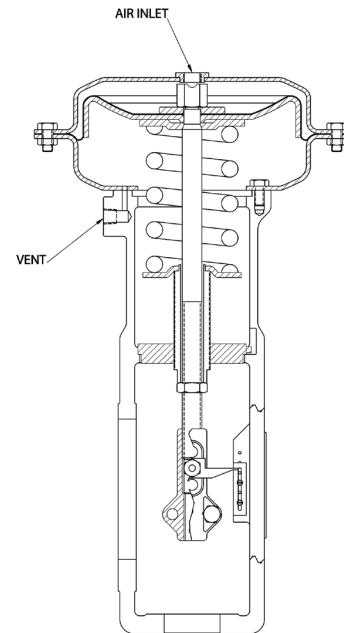

Read these instructions carefully before installation or servicing.

WARNING !

FOR YOUR SAFETY AND PROTECTION, IT IS IMPORTANT THAT THE FOLLOWING PRECAUTIONS BE TAKEN PRIOR TO REMOVING THE VALVE FROM SERVICE OR BEFORE ANY DISASSEMBLY OF THE VALVE:

1. At all times during this procedure, keep hands out of the valve. A remotely actuated valve could close at any time and result in serious injury.
2. Know what media is in the line. If there is any doubt, check with the proper authority.
3. Wear any protective clothing or equipment normally required when working with the media involved.
4. Depressurize the line and valves as follows:
 - a. Open the valve and drain the line.
 - b. Close and open the valve to relieve any residual pressure that may be in the valve prior to removing the valve from service.
 - c. After removal and prior to any disassembly, drain any remaining media by placing the valve in a vertical position and carefully opening and closing the valve several times.
5. The practical and safe use of this product is determined by both the trim and body ratings. Read the name tags and check both ratings. This product is available with a variety of trim materials. Some of the trim materials have pressure ratings that are less than the body ratings. All of the body and trim ratings are dependent on valve type and size, trim material, bolting material, and temperature. Do not exceed these ratings.

TABLE OF CONTENTS

Description 3
Disassembly 3
Assembly 3
 Diaphragm Subassembly 3
 Spring Barrel/Lower Diaphragm Case
 Subassembly 3
 #1 and #2 Spring Barrel 3
 #3 Spring Barrel 4
 Final Assembly 4
 All Actuators. 4
Adjusting the Actuator 4
**General Instrumentation Mounting
Guidelines 5**
 Globe Valve Orientation 5
 Actuator Orientation 5
 Positioner Mounting/Spring and
 Diaphragm Actuators 5
 Tubing 5
**Changing Actuator from Direct Acting
to Reverse Acting. 5**

DIAGRAMS/TABLES

Typical Nameplate 4
Parts Identification (Fig. 1) 6
 Table 1. 6

These instructions provide information about safe handling and operation of the valve and are subject to change without notice.

DESCRIPTION

Model DA, DB, DC, DD actuators are linear-motion spring-return pneumatic diaphragm actuators, primarily intended for use with rising stem type valves. In the “normal” position (no air pressure on the diaphragm), the direct actuator holds the stem in its retracted position by means of a mechanical spring. Increasing air pressure in the upper diaphragm chamber thrusts the actuator stem downward and compresses the spring.

Mounted on pull-stem-to-open valve body assemblies, the direct actuator closes the valve when increasing air pressure is applied to the upper diaphragm chamber. Mounted on push-stem-to-open valve body assemblies, the direct actuator opens the valve when increasing air pressure is applied to the upper diaphragm chamber. An external spring adjustment permits the spring compression to be changed within predetermined limits. These actuators are manufactured for and applied to meet the requirements of the valve and the service conditions as specified in the sales order, and are ordinarily shipped mounted on the valve body subassembly and with all accessory equipment mounted, piped, and adjusted.

Max. Pressure Rating: 65 psig

Actuator Temp. Rating: - 20°F to + 180°F
(-29°C to +82°C)

Action: Air-to-close on down seated valves

Air Connection: 3/8” (9 mm) NPT

DISASSEMBLY

1. Remove all pneumatic and electric inputs to the actuator.
2. Disconnect and remove all accessories and input lines to the actuator.
3. Disconnect the split coupling (26) engaging the valve stem and spring stem (7) and the limit stop nut (28).
4. Remove all spring compression by unscrewing the spring adjuster (11) [by applying a wrench at the bottom of the adjuster with #1 or #2 spring barrels, or by inserting a screwdriver in the slot of the case and turning the adjuster until the spring (6) is at free length (unloaded)].

CAUTION: Do not proceed further with disassembly without clearly determining that the spring is fully decompressed and loose.

5. Remove the diaphragm case cap screws (17) and nuts (18) and lift off the upper diaphragm case (4).
6. Withdraw the diaphragm subassembly.

Note: Do not disassemble the diaphragm subassembly unless there is evidence of damage or failure to the diaphragm (2) or other subassembly components, or disassembly is for the purpose of reversing the action of the actuator.

7. Remove the spring (6), the spring adjusting button (21), and the spring adjuster (11) and the barrel bridge (8) as a unit.

Note: Step #8 need not be performed unless there is apparent component damage or disassembly is for the purpose of reversing the action of the actuator.

8. Remove the lower case cap screws (20) and lift off the lower diaphragm case (5).

ASSEMBLY

Note: This instruction assumes that assembly is starting with all components disassembled. In reassembly, disregard those instructions that do not apply.

Diaphragm Subassembly

1. Place the spring stem (7) in a soft jawed vise, gripping it above the spring adjustment (larger diameter) threads.
2. Drop the diaphragm back-up plate (15) tapered bore down, onto the spring stem (7).
3. Drop the piston (3), skirt extending down, onto the spring stem (7).
4. Next, drop the diaphragm “O” ring (25), the diaphragm (2), the diaphragm disc (22), and the diaphragm button (16), down on the spring stem (7) in that order.
5. Apply loctite #271 to the spring stem threads. Then install the spring stem nut (19). Apply 90 lb-ft (122 Nm) of torque to the 5/8” (16 mm) nut used for the smaller case sizes and 200 lb-ft (271 Nm) to the 7/8” (22 mm) nut used for the 240 in2 (1548 cm2) case sizes.

Spring Barrel/Lower Diaphragm Case Subassembly

1. Restrain the spring barrel (1) by strapping it down to an assembly bench or by gripping the lower end lightly in a bench vise.
2. Place the lower diaphragm case (5) on the upper face of the spring barrel (1) so that the holes in the bolt circle are in alignment and concentrically positioned.
3. Install the case cap screws (20), using good bolt circle tightening procedure. Tighten the cap screws to 22–26 lb-ft (30–35 Nm).

Actuators with #1 and #2 Spring Barrel:

1. Screw the spring adjuster (11) into the barrel bridge (8) until the adjuster extends approximately 3/4” (19 mm) beyond the bottom of the bridge. Heavily coat the upper shoulder of the spring adjuster (11) which engages the spring adjusting button (21) with any all-purpose grease.
2. Lower the barrel bridge subassembly into the spring barrel subassembly taking care to assure

that the torque arrestor projection tab on the barrel bridge (8) is engaged in the torque arrestor cavity in the spring barrel (1) and that the barrel bridge (8) is properly seated in the machined recess of the spring barrel (1).

3. Lower the spring adjuster button (21) down onto the upper shoulder of the spring adjuster (11).
4. Lower the spring (6) down onto the spring adjuster button (21).
5. Lower the diaphragm subassembly down through the spring adjuster (11) until the skirt of the piston (3) makes contact with the bottom of the lower diaphragm case (5).
6. Screw the spring adjuster (11) up into the barrel bridge (8) until the piston rises a distance equal to the actuator stroke plus 1/4" (6 mm).
7. Screw the limit stop nut (28) onto the lower end of the spring stem (7) until it makes contact with the spring adjuster (11)

Actuators with #3 Spring Barrel

1. Thread the spring adjuster screw (30) into the spring adjuster (11) until the screw extends approximately 3/4" (19 mm) beyond the adjuster's upper face.
2. Thread on jam nut (32) onto the other end of the spring adjuster screw (30), followed by the barrel bridge (8), and then the second jam nut (32) positioning and securing the bridge with the jam nuts so the screw extends 3/4" (19 mm) below the bottom face of the bridge.
3. Lower the bridge barrel/spring adjuster subassembly into the spring barrel (1) taking care to assure that the barrel bridge (8) is properly seated in the machined recess of the spring barrel (1).
4. Place the spring adjuster thrust bearing (31) and spring adjuster button down onto the top of the spring adjuster. Lower the spring (6) down on the spring adjuster button (21).
5. Lower the diaphragm assembly down through the spring adjuster screw (30) until the skirt of the piston (3) makes contact with the bottom of the lower diaphragm case (5).
6. Rotate the spring adjuster (11) with a screwdriver until the piston rises a distance equal to the actuator stroke plus 1/4" (6 mm).
7. Screw the limit stop nut (28) onto the lower end of the spring stem (7) until it makes contact with the bottom of the spring adjuster screw (30). Give it one additional turn.

Final Assembly

All Actuators

8. Orient the diaphragm (2) so that the bolt circle holes are lined up with the holes in the lower diaphragm

case (5). Take care to assure that the diaphragm (2) is properly nested between the piston (3) and the lower diaphragm case (5) and that there is no twisting or binds.

9. Place the upper diaphragm case (4) over the diaphragm (2) lining up the flange bolt holes properly.
10. Install the diaphragm case cap screws (17) and the cap screw nuts (18). Tighten the cap screws (17) to 22–26 lb·ft (30–35 Nm).

ADJUSTING THE ACTUATOR

Actuator Bench Setting is accomplished while the actuator is not attached to the valve. The initial Bench setting "Bench Init" is identified on the valve identification tag (27) as the lower number listed in the Bench Set block and is achieved by turning the spring adjuster (11) clockwise to compress the spring (6). Turn the spring adjuster several turns until the spring begins to compress. Check the setting by slowly increasing the air supplied to the diaphragm case. When the actuator stem begins to move upward, stop increasing the air supplied to the diaphragm case. This is the actuator Bench Init value. If it is not the required Bench Init, reduce the diaphragm case pressure to zero and readjust the spring adjuster clockwise to increase the Bench Init and counter-clockwise to reduce it. Slowly increase the air pressure to the diaphragm case to recheck the pressure when the actuator begins to move. Once the proper Bench Init has been set, check that the actuator has the proper upper Bench setting for the travel. Increase the air pressure to the diaphragm case to the Bench Init value. Slowly increase the air pressure further while watching the actuator stroke scale (23).

CAUTION: Do not increase the air pressure above recommended maximum air pressure for the actuator.

When the actuator reaches its proper travel as indicated by the stroke scale (23), note the air pressure. This is the upper Bench setting of the actuator. The actuator should stroke the full travel smoothly with no hesitations throughout its entire stroke.

⊕

SERIAL NO.

CATALOG NUMBER

ACTUATOR

SIZE CLASS

BODY MAT'L

CHAR/Cv

TRIM MAT'L

PACKING

MAX. TEMP. F

FAILS STROKE

BENCH SET

PUSH DOWN TO

RTG. 100 F

KOSO HAMMEL DAHL

⊕

Typical Nameplate

Note: If actuator action or flow conditions are changed, pressures listed on nameplate no longer apply. If application changes, new valve trim may be required.

GENERAL INSTRUMENTATION MOUNTING GUIDELINES

Note: Specific customer instructions may supersede these general guidelines; please consult the factory order or your supervisor for specific instructions.

Globe Valve Orientation: View the valve such that the piping flow direction is from left to right. The valve inlet will now be on the left side and the valve outlet will be on the right side. The side of the valve you are looking at is the **Front** of the valve. View the valve such that the piping flow direction is from right to left. The valve inlet will now be on the right side, and the valve outlet will be on the left side. The side of the valve you are looking at is the **Back** of the valve.

Actuator Orientation: When looking at the side of the valve, the stroke scale mounting tab of the cast actuator yoke will always be located at the right side of the valve, and the slot in the actuator leg will be located on the left side.

Actuator side-mounted handwheels will be mounted on the back side of the actuator yoke.

Actuator air supply is to be set at 5 psig above the upper range of the actuator.

Positioner Mounting/Spring and Diaphragm Actuators: The positioner will always be mounted on the Front side of the valve and positioned to the left of the actuator center line. The distance the positioner is placed left of the actuator center line is determined by the valve stroke

The positioner filter air regulator will be close nipple mounted to the actuator. Solenoid valves with manual reset will be bracket mounted to the yoke of the actuator.

Limit switches will be bracket mounted to the actuator yoke and located on the back side of the valve and to the right of the actuator center line while looking at the front side of the valve.

Tubing: Standard tubing will be elastomer covered rubber hose with brass push-type fittings. All tubing will be piped as close to the actuator spring barrel as possible. Metal tubing will have at least two right hand bends from connector to connector to allow for flexibility.

CHANGING ACTUATOR FROM DIRECT ACTING TO REVERSE ACTING

1. Completely disassemble the actuator as explained previously in steps 1 through 8 under "DISASSEMBLY."
2. Put aside the spring bridge (8), spring adjuster (11), and limit stop nut (28), which will no longer be needed.

3. Reassemble the actuator as explained IMO - Type R (Reverse-Acting Linear Spring Diaphragm Actuators) in steps 1 through 4 under "ASSEMBLY," using the following reverse actuator parts: packing box flange (8), lower case gasket (10), spring adjuster (11), packing box (13), and packing box "O" rings (14). Make sure that the diaphragm (2), piston (3), diaphragm disc (22), piston back-up plate (15), diaphragm button (16), and diaphragm "O" ring are inverted.
4. Readjust the actuator as specified in IMO - Type R. ■

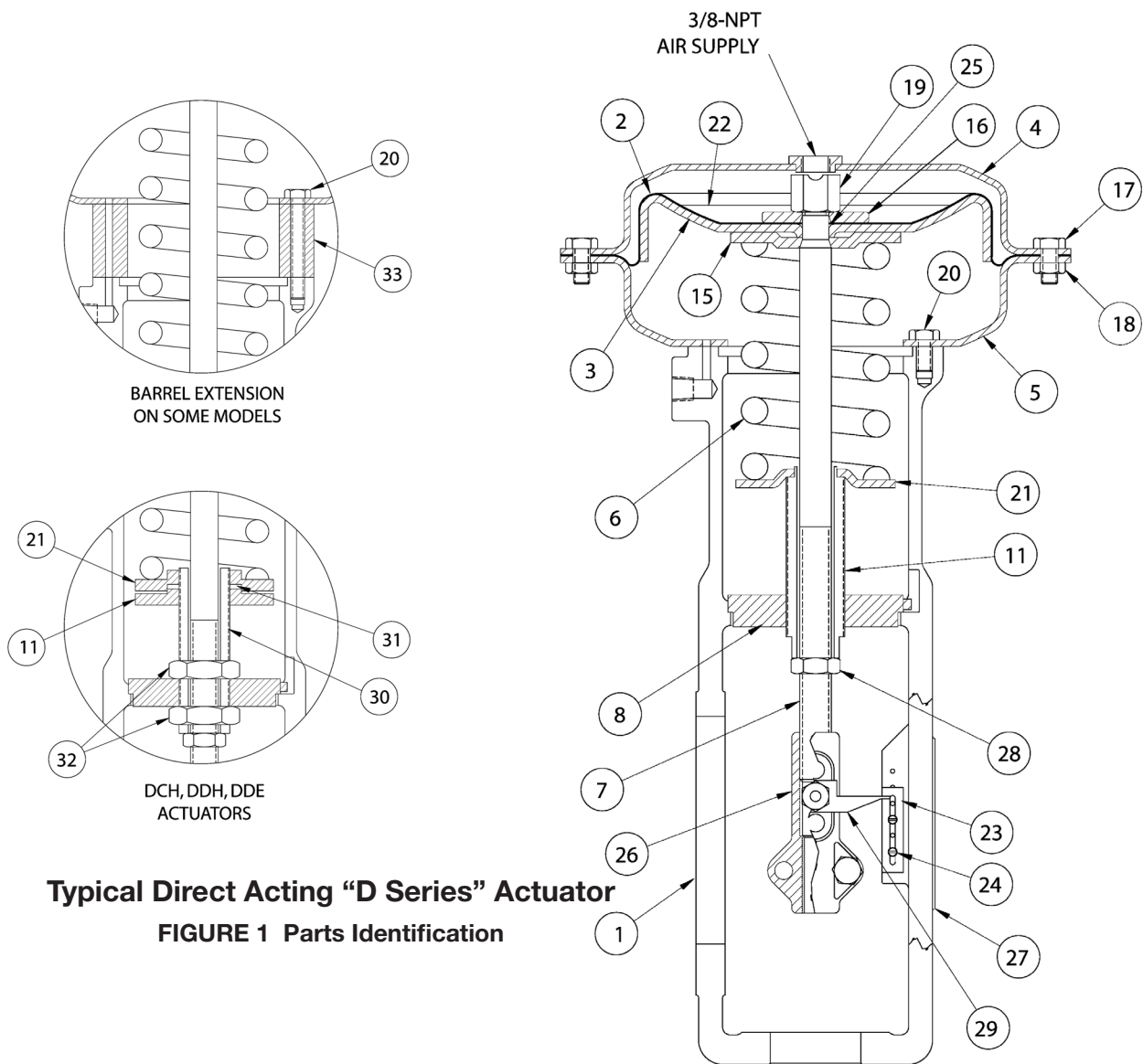

Typical Direct Acting "D Series" Actuator
FIGURE 1 Parts Identification

Table 1

Part No.	Part Name	Qty.	Part No.	Part Name	Qty.	Part No.	Part Name	Qty.
1	Spring Barrel	1	16	Diaphragm Button	1	26	Split Coupling	1
2	Diaphragm	1	17	Hex Head Cap Screw	A	27	Identification Tag	1
3	Piston	1	18	Hex Nut	A	28	Stop Nut	1
4	Upper Diaphragm Case	1	19	Up Travel Stop	1	29	Travel Indicator	1
5	Lower Diaphragm Case	1	20	Hex Head Cap Screw	B	30	Spring Adjuster Screw	1 ²
6	Spring	1	21	Spring Adjuster Button	1	31	Spring Adjuster Thrust Bearing	1 ³
7	Spring Stem	1	22	Diaphragm Disc	1 ¹	32	Jam Nut	13
8	Barrel Bridge	1	23	Travel Indicator Scale	1	33	Spring Barrel Extension	1 ⁴
11	Spring Adjuster	1	24	Self Tap Screw	6			
15	Piston Back-up Plate	1 ¹	25	Diaphragm O-ring	1			
A: 56 in ² case (16) 140 in ² case (24)			B: 56, 84, and 140 in ² case (6) 240 in ² case (10)			Note: 1. Except DDH. 2. DCH and DDH only. 3. DCH and DDH. 4. DCF and DCE only.		

KOSO HAMMEL DAHL
 4 Manley Street
 W. Bridgewater MA 02379

CONTROL VALVES

KOSO HAMMEL DAHL

Telephone: 508.584.1199
 Fax: 508.584.2525
www.hammeldahl.com